

Performance

Rated Capacity	2,500 kg
Maximum Lift Height	5.6 m
Load at Max Height	2,000 kg
Maximum Forward Reach	3.3 m
Load at Max Reach	800 kg
Lift Speed (boom retracted)	
Up	6.6 sec
Down	8.2 sec
Boom Speed (extended/retracted)	
Extended	6.7 sec
Retracted	3.5 sec
Top Travel Speed	24 km/h
Outside Turning Radius	3.2 m
Operating Weight (no attachment)	5010 kg

Standard Specifications

Engine

Make and Model	Deutz TD 2.9 L L4 - Stage IIIB
No. of Cylinders	4
Displacement	2.9 L
Standard engine gross power	55 kW
Maximum Torque @ 1800 rpm	260 Nm
Fuel Tank Capacity	91 L

Transmission

- 1 speed FWD/REV Hydrostatic
- 4-Wheel drive

Axles

- High bias limited slip differential on front axle
- Planetary on front and rear axles.

Brakes

- Service brakes are inboard wet disc brakes on front axle
- Parking brake external disc and calliper on input shaft of front axle

Tyres

• Standard	12 x 16.5 Pneumatic
• Optional	12 x 16.5 Foam-Filled
	14 x 17.5 Foam-Filled
	14 x 17.5 Pneumatic
	10.5 x 18 AG Pneumatic

Cab

- EROPS and FOPS fully glazed all weather cab
- 2 way adjustable mechanical suspension seat

Steering 4-Wheel

- Power steering with steering wheel spinner
- Two wheel/four wheel/crab steer with rear wheel assisted alignment

Instruments

- Hourmeter
- Steering mode
- Engine coolant temperature
- Fuel gauge
- Alternator gauge dicators, including fault codes
- Parking brake indicator
- Travel speed
- Engine speed
- Vehicle and engine system

Hydraulic System-Implement

Capacity	60.5 L
----------	--------

- Single-section gear pump
- Auxiliary hydraulics used for all attachments equipped with cylinders or other hydraulic components
- Maximum pump flow is 72.3 L/min

Accessories & Options

- Brick Guard
- Air Conditioning
- Block Heater
- Hydraulic Quick Switch
- Rear Auxiliary Hydraulics
- Universal Skid Steer Coupler
- Boom brushes
- Tow Hitch w/automatic pin & trailer plug
- Pre-cleaner
- Battery Disconnect Switch
- Road Light Package
- Work Light Package
- Skylight/Rear Wiper Package
- Radio Ready Kit
- Tow Hitch w/trailer plug
- Reversing fan
- Molded Floor Mat
- Fenders

Attachments

Standard Carriage	1.3 m
Side-Tilt Carriage	1.2 m
Pallet Forks	51 mm x 102 mm x 1.2 m
Lumber Forks	38 mm x 152 mm x 1.5 m
Cubing Forks	51 mm x 51 mm x 1.2 m
General Purpose Bucket	1.85 m, 0.76 m ³
Light Material Bucket	1.8 m, 1.29 m ³
Grapple Bucket	1.8 m, 0.76 m ³
Lifting Hook	

Devon

Richmond Walk, Plymouth, Devon, PL1 4LT
01752 500848
info@ltpoweredaccess.co.uk

Cornwall

Plot 1, Phase 1, United Downs, Industrial Park,
Redruth, Cornwall, TR16 5HY
01209 822216
info@ltpoweredaccess.co.uk

Dimensions

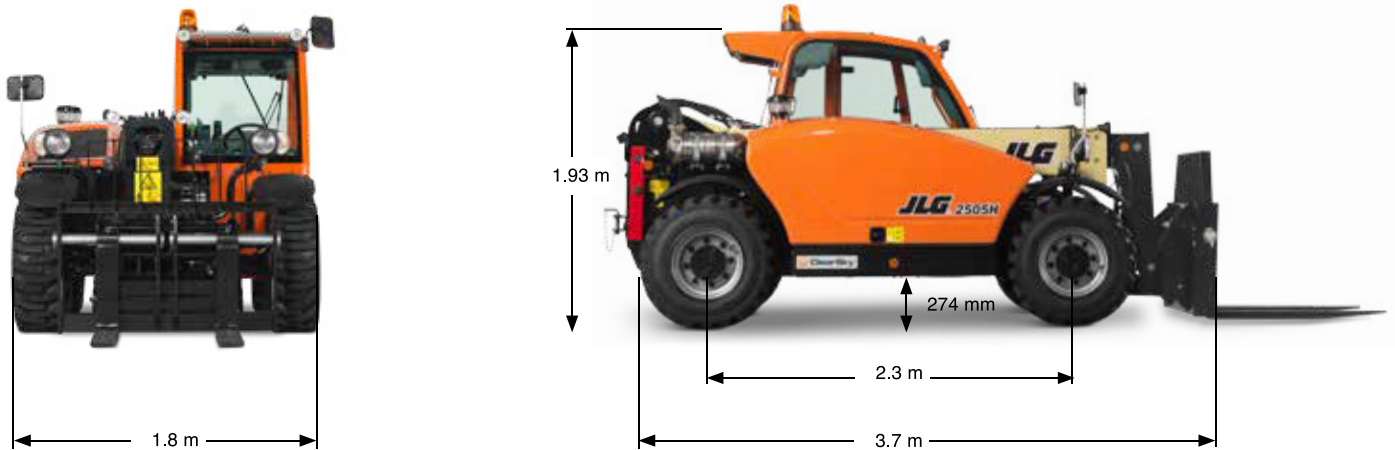

Load Chart and Dimensions

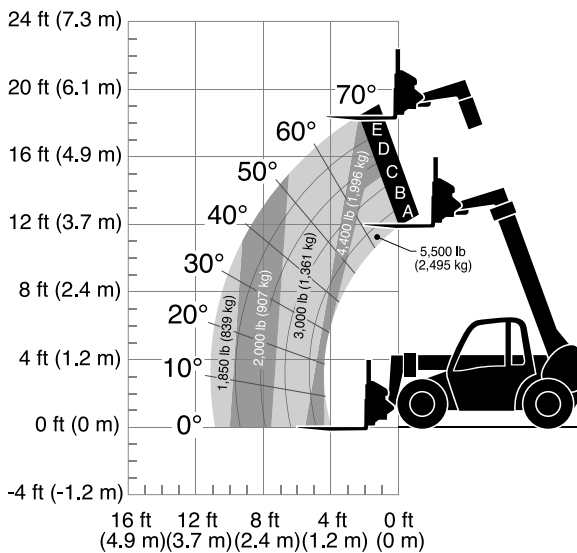

Devon

Richmond Walk, Plymouth, Devon, PL1 4LT
01752 500848
info@ltpoweredaccess.co.uk

Cornwall

Plot 1, Phase 1, United Downs, Industrial Park,
Redruth, Cornwall, TR16 5HY
01209 822216
info@ltpoweredaccess.co.uk